

- Tension/compression load cell
- 3000 divisions O.I.M.L. R60 class C
- Measuring element from Steel alloy
- Protected IP 67 (EN 60529)
- Protected against corrosion by nickel-plated treatment
- Applications:
  - Suspended weighing in Tanks, Hoppers and Belt Conveyor Scales
  - Asphalt and Concrete Plants
  - Force measurement in Test Equipment
  - Crane scales

- Wägezelle für Druck/Zugkraft
- 3000 Teile O.I.M.L. R60 Klasse C
- Messkörper aus Stahl
- Schutzart IP 67 (EN 60529)
- Korrosionsschutz durch Vernickelung
- Applikationen:
  - Schwebende Wägetrichter und Wägebändern
  - Asphalt- und Betonanlagen
  - Kraftmessung bei Testmaschinen
  - Hängende Verwiegung

Model Modell	Nominal capacity Nennlast Ln	Accuracy class Accuracy class n. OIML	Minimum division Kleinster Teilungswert vmin	Service load Gebrauchslast 150% Ln	Safe load Grenzlant 300% Ln
620 50 kg	50 kg	3000	5 g	75 kg	150 kg
620 100 kg	100 kg	3000	10 g	150 kg	300 kg
620 150 kg	150 kg	3000	15 g	225 kg	450 kg
620 200 kg	200 kg	3000	20 g	300 kg	600 kg
620 300 kg	300 kg	3000	30 g	450 kg	900 kg
620 500 kg	500 kg	3000	50 g	750 kg	1500 kg
620 750 kg	750 kg	3000	75 g	1125 kg	2250 kg
620 1000 kg	1000 kg	3000	100 g	1500 kg	3000 kg
620 1500 kg	1500 kg	3000	150 g	2250 kg	4500 kg
620 2000 kg	2000 kg	3000	200 g	3000 kg	6000 kg
620 3000 kg	3000 kg	3000	300 g	4500 kg	9000 kg
620 5000 kg	5000 kg	3000	500 g	7500 kg	15000 kg
620 6000 kg	6000 kg	3000	600 g	9000 kg	18000 kg

# MODEL 620

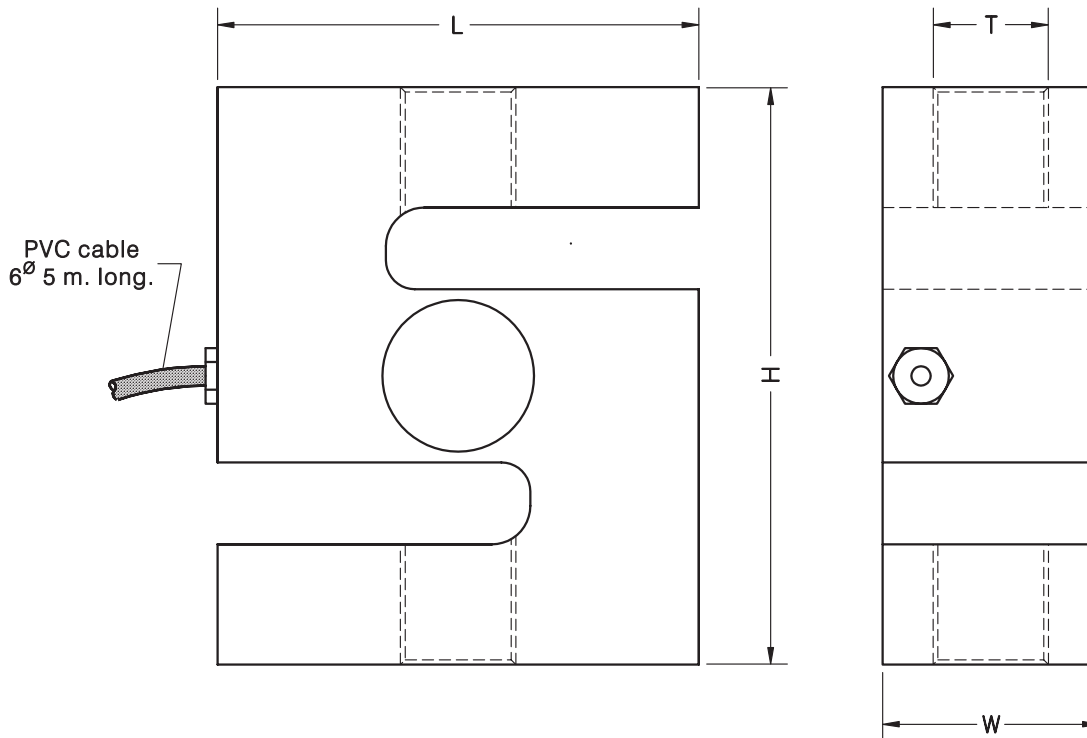

Nominal load Nennlast	L	H	T	W	Transport weight Transportgewicht
50...1000 kg	62.1	80	M12x1.75	19	0.7 kg
1500-2000 kg	70	90	M16x2	32	1.3 kg
3000...6000 kg	100	120	M24x2	45	3.3 kg

Dimensiones en mm. *Dimensions in mm.*

SPECIFICATIONS			TECHNISCHE DATEN
Nominal capacities (Ln)	50-100-150 200-300-500 750-1000-1500 2000-3000 5000-6000	kg	Nennlasten (Ln)
Accuracy class	3000	n. OIML	Genauigkeitsklasse
Minimum dead load	0	%Ln	Minimale Vorlast
Service load	150	%Ln	Gebrauchslast
Safe load limit	300	%Ln	Grenzlant
Total error	< ±0.017	%Sn	Zusammengesetzter Fehler
Repeatability error	< ±0.015	%Sn	Wiederholgenauigkeit
Temperature effect: on zero on sensitivity	< ±0.01 < ±0.006	%Sn/5 °C %Sn/5 °C	Temperaturfehler: Nullpunkt Kennwert
Creep error (30 minutes)	< ±0.016	%Sn	Kriechfehler (30 min)
Temperature compensation	-10...+40	°C	Nenntemperaturbereich
Temperature limits	-30...+70	°C	Arbeitstemperaturbereich
Nominal sensitivity (Sn)	2 ±0.1%	mV/V	Nennkennwert (Sn)
Nominal input voltage	10	V	Nom. Speisespannung
Maximum input voltage	15	V	Max. Speisespannung
Input impedance	400 ±20	Ω	Eingangswiderstand
Output impedance	350 ±3	Ω	Ausgangswiderstand
No load output	< ±2	%Sn	Nullsignaltoleranz
Insulation resistance	> 5000	MΩ	Isolationswiderstand
Maximum deflection (at Ln)	0.3-0.5	mm	Nennmessweg (bei Ln)

## ELECTRICAL CONNECTION ELEKTRISCHER ANSCHLUSS:

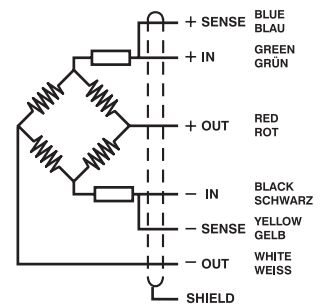

«SENSES»: 2 additional wires to maintain a constant voltage supply at the load cell when used with proper instrumentation. Use specially when long wires and wide temperature range. SHIELD: Not connected to transducer body.

## «OUTPUT SIGNS FOR TENSION APPLICATION»

"SENSE-Leitung": zwei zusätzliche Adern, um eine konstante Spannungsversorgung an der Wägezelle zu gewährleisten, wenn entsprechende Elektronik verwendet wird. Speziell bei langen Leitungen und grossem Temperaturunterschied auf der Leitung. SCHIRM: nicht am Wägezellenkörper angeschlossen.

## «SIGNALPOLARITÄT FÜR ZUG-KRAFT»

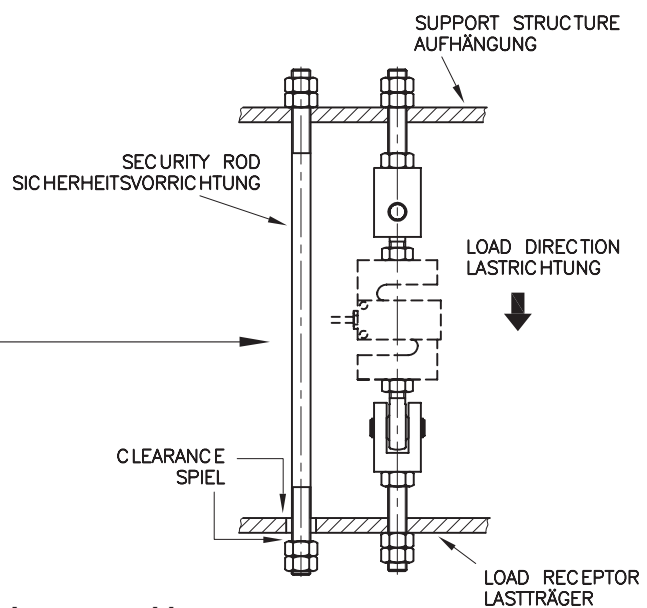
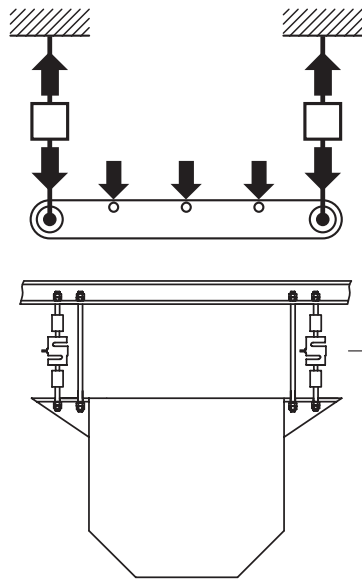
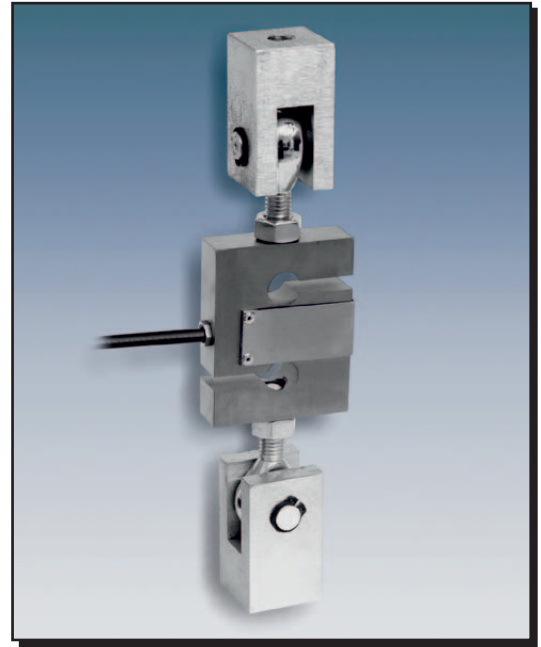
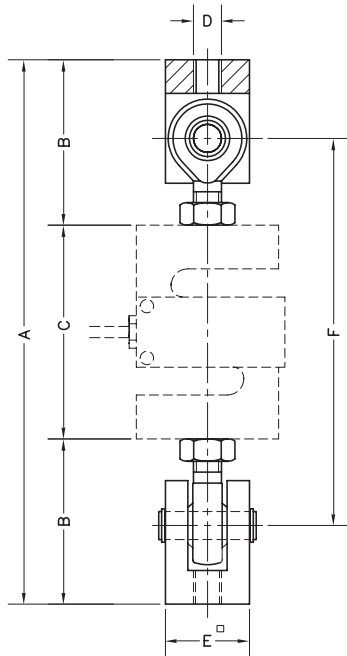
**TENSION ACCESSORIES FOR MODEL 620**  
**ZUGKRAFTZUBEHÖR FÜR MODELL 620**

- Each accessory contains a set of the top and bottom.
- Das Zubehör beinhaltet ein oberen und ein unteren Satz von Teilen

Accessory Zubehör	Nominal load Nennlast	A	B	C	D	E <sup>□</sup>	F	Ultimate load Grenzlast	Transport weight Transportgewicht	Material
<b>TE12x1.75</b>	50...1000 kg	246	83	80	M12x1.75	35	158	2580 kg	1.4 kg	Steel zinc-plated Verzinkter Stahl
<b>TE16x2</b>	1500-2000 kg	290	100	90	M16x2	50	184	3710 kg	3.5 kg	
<b>TE24x2</b>	3000-5000-6000 kg	398	139	120	M24x3	60	246	8150 kg	7.8 kg	

Dimensions in mm. Abmessungen in mm.

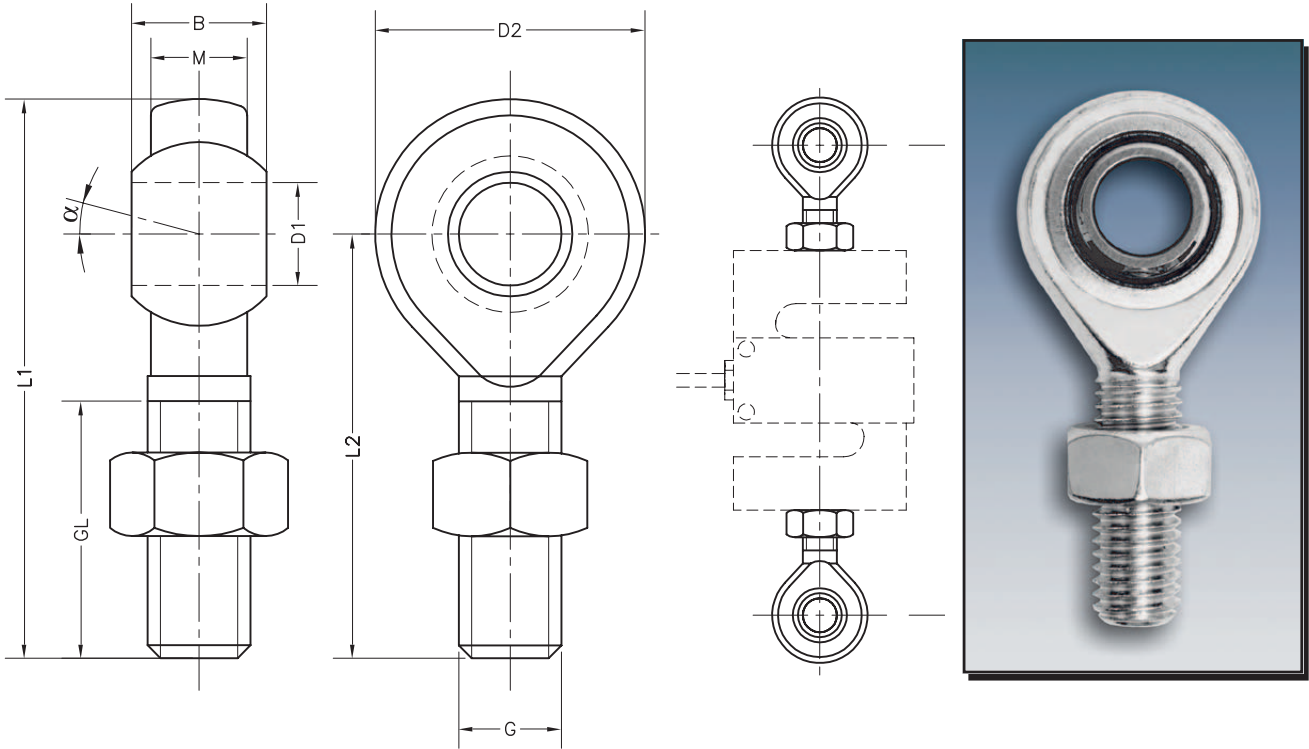
**ROD ENDS FOR MODEL 620**  
**GELEMKKÖPFE FÜR MODELL 620**

- **Material: Steel zinc-plated**
- **Each accessory RO includes a set of: 2 rod ends and 2 nuts**

- **Material: Verzinkter Stahl**
- **Jedes Zugkraftzubehör beinhaltet ein Satz von: 2 Gelenkköpfe und 2 Muttern**

RO Accessories Dimensions / RO Abmessungen Zubehör												
Accessory Zubehör	Capacity/ Nennlast (kg)	D2	B	M	D1	L1	L2	GL	G	$\alpha$	F	Trans. weight Transportgewicht
<b>R012x1.75</b>	50...1000	32	16	12.0	Ø12	70	54	33	M12x1.75	13°	158	0.2 kg
<b>R016x2</b>	1500-2000	42	21	15	Ø16	87	66	40	M16x2	15°	184	0.7 kg
<b>R024x2</b>	3000-5000-6000	64	20	17	Ø25	126	94	53	M24x2	-	246	1.3 kg

Dimensions in mm. Abmessungen in mm.