

2026

Operating instructions measuring amplifier A40U



17.02.2026

Trachsler Electronics GmbH

Mess- und Wägetechnik, Cloud-Anbindungen
Haslistrasse 12a, CH-8554 Wigoltingen
Tel. +41/44 970 31 65
Fax +41/44 970 31 66



Trachsler Electronics GmbH
Mess- und Wägetechnik, Cloud-Anbindungen
Haslistrasse 12a, CH-8554 Wigoltingen
Tel. +41/44 970 31 65
Fax +41/44 970 31 66



Table of contents

General information.....	2
Operation and introduction	3
Meaning of the LEDs on the front panel of the device.....	4
Important steps before installing on a computer.....	4
Install device driver	5
Connect to the device via the setup programme	6
Select device identifier	7
Measurement amplifier settings	8
Perform device calibration	9
Channel activation, user designation, user unit	10
Perform user scaling.....	11
Multi-point scaling	11
Polynomial scaling.....	13
Summation and averaging	14
Activate and set limit values	15
Load / save settings.....	17
Page view Printer selection Print settings	18
Save tare and zero values in a power failure-proof manner	22
Measured values [mV/V] Zero-adjustable.....	23
Perform firmware update	24
Measurement value display in the setup program.....	26
Switching the device on/off	27
Nameplate.....	27
Sensor connection.....	28
Check whether an update is available.....	29
Select user language	30
Technical specifications.....	31

General information

The DMS A40U measuring amplifier with USB interface can be used to measure and monitor various sensors.

The measuring amplifier can be scaled using an 11-point scale or a polynomial function with 4 constants.

Up to 8 output channels and 8 limit value pairs can be freely selected and activated:

Gross CH1 [user-scaled]	scaled gross value with specified unit
Gross CH2 [user-scaled]	scaled gross value with specified unit
Gross CH3 [user-scaled]	scaled gross value with specified unit
Gross CH4 [user-scaled]	scaled gross value with specified unit
Net CH1 [user-scaled]	scaled net value with specified unit
Net CH2 [user-scaled]	scaled net value with specified unit
Net CH3 [user-scaled]	scaled net value with specified unit
Net CH4 [user-scaled]	scaled net value with specified unit
Tare CH1 [user-scaled]	scaled tare value with specified unit
Tare CH2 [user-scaled]	scaled tare value with specified unit
Tare CH3 [user-scaled]	scaled tare value with specified unit
Tare CH4 [user-scaled]	scaled tare value with specified unit
Measured value CH1 [mV/V]	absolute measured value in [mV/V]
Measured value CH2 [mV/V]	absolute measured value in [mV/V]
Measured value CH3 [mV/V]	absolute measured value in [mV/V]
Measured value CH4 [mV/V]	absolute measured value in [mV/V]
+ Peak value CH1 [user-scaled]	positive peak value with specified unit
+ Peak value CH2 [user-scaled]	positive peak value with specified unit
+ Peak value CH3 [user-scaled]	positive peak value with specified unit
+ Peak value CH4 [user-scaled]	positive peak value with specified unit
- Peak value CH1 [user-scaled]	negative peak value with specified unit
- Peak value CH2 [user-scaled]	negative peak value with specified unit
- Peak value CH3 [user-scaled]	negative peak value with specified unit
- Peak value CH4 [user-scaled]	negative peak value with specified unit
Sum CH1...CH4 [user-scaled]	Sum of the measured values of the active channels
Sum CH1...CH4 [mV/V]	Sum of the measured values of the active channels
Average CH1...CH4 [user-scaled]	Sum of the measured values of the active channels
Average CH1...CH4 [mV/V]	Sum of the measured values of the active channels
AD converter raw count CH1	24-bit converter raw count
AD converter raw count CH2	24-bit converter raw count
AD converter raw count CH3	24-bit converter raw count
AD converter raw count CH4	24-bit converter raw count
Device temperature in °C	Device temperature only measurable when sensor CH1 is connected

Operation and introduction

The device has an «ON» button that is used to switch it on and off.

Press the button to switch the device on and hold it down for approx. 2-3 seconds to switch it off.





Instructions for handling the device that must be followed:

- The device has protection class IP54. Suitable moisture protection must be provided for outdoor measurements.
- Clean the unit only with water and a little soap. Never use methylated spirits, thinners, acetone or similar cleaning agents.
- Before opening the device, the mains plug must be disconnected so that the device is de-energised.

Meaning of the LEDs on the front panel of the device

Three LEDs indicate the operating status of the device:

-  **Error** There are two possible causes for the LED lighting up:
 1. The sensor(s) connected to the device have not been assigned, or have been assigned incorrectly, or the measuring amplifier is overloaded.
 2. Following a firmware update, the device is in a state where it is waiting for the new firmware. If the flash memory has not yet been deleted, the device can be operated again after switching the power on and off five times. Otherwise, the new firmware must be loaded. (Perform firmware update)
-  **Remote** The device has established a connection to the computer and the login command has been executed correctly.
-  **Betrieb** The device is powered and switched on.

Important steps before installing on a computer

Before connecting the measuring amplifier to your computer for the first time, the setup programme must first be installed on the computer with administrator rights.

This will provide the operating system with the drivers/information required for operation.

If the measurement amplifier is connected to the computer before the drivers are installed, problems may arise later and the measurement amplifier will not be found by the setup programme. Please read the next chapter for more information.

Install device driver

The files required to operate the device are installed during installation by the corresponding setup programme. You can find them under:

C:\Windows\inf\Trachsler Electronics GmbH\

TE_Amplifier.cat is the catalogue file and the **usb_driver.inf** the corresponding information file.

The actual driver "Usbser.sys" is provided by Microsoft and should have been installed with Windows.



If Windows is unable to install the device drivers or the device cannot be found, open Device Manager and search for the virtual COM port in the adapter settings. Select Reinstall driver and navigate to the path listed above. Confirm your entry and wait until Windows has entered the data.

Connect to the device via the setup programme

Select the «USB interface» from the list of interfaces:

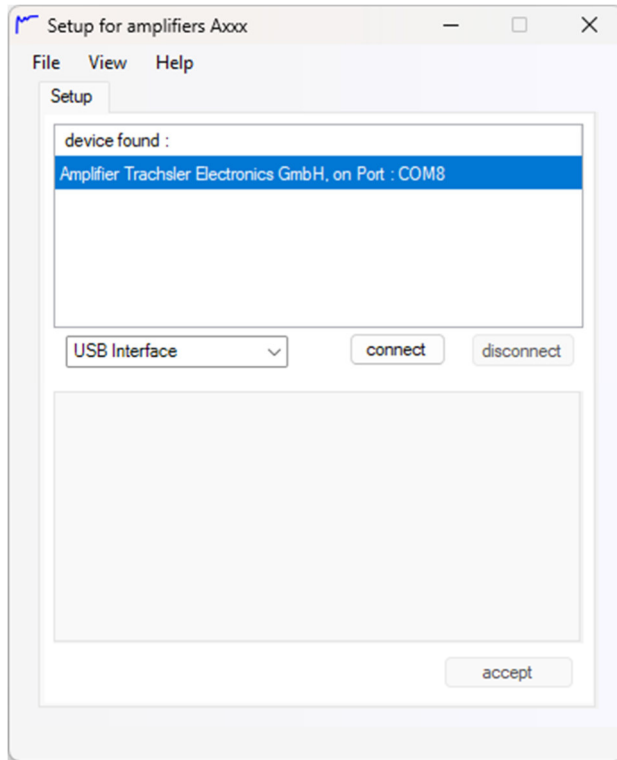

The USB 2.0 interface is provided as a COM port. Multiple connected devices are listed.

Select «Connect» to start communication with the measurement amplifier.

Select device identifier

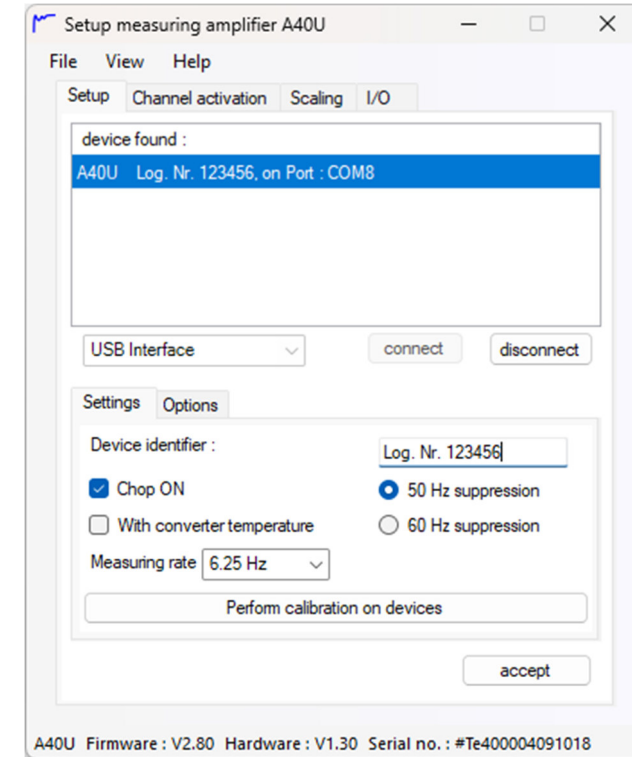

★ You can assign an identifier to the device. This will be displayed in the list of found devices, among other places.

Measurement amplifier settings

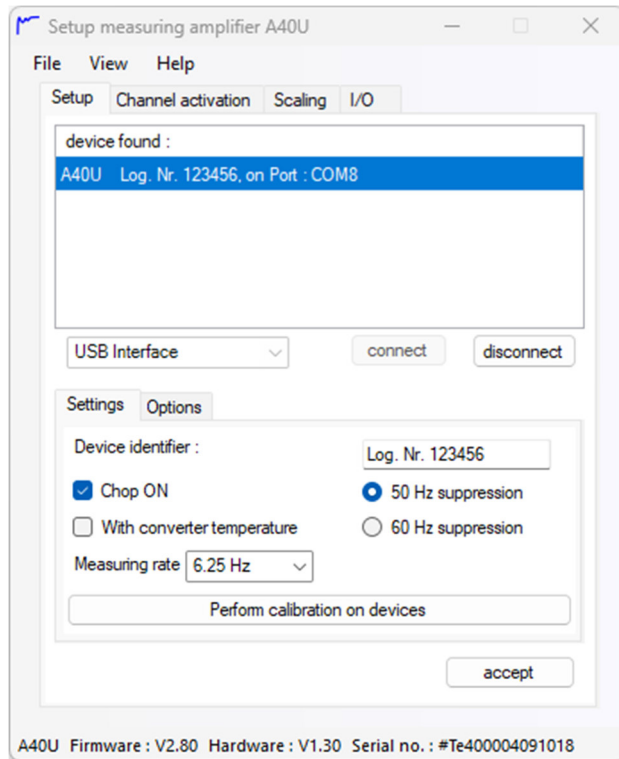

Chop ON: This setting is used to minimise offset drift when the measurement rate is less than 300 Hz.

If required, the transducer temperature of Channel 1 can be displayed in the setup programme.

Noise reduction (filter) can be set to the currently active mains frequency.

The measurement rate is usually set in the measurement programme used.

Perform device calibration

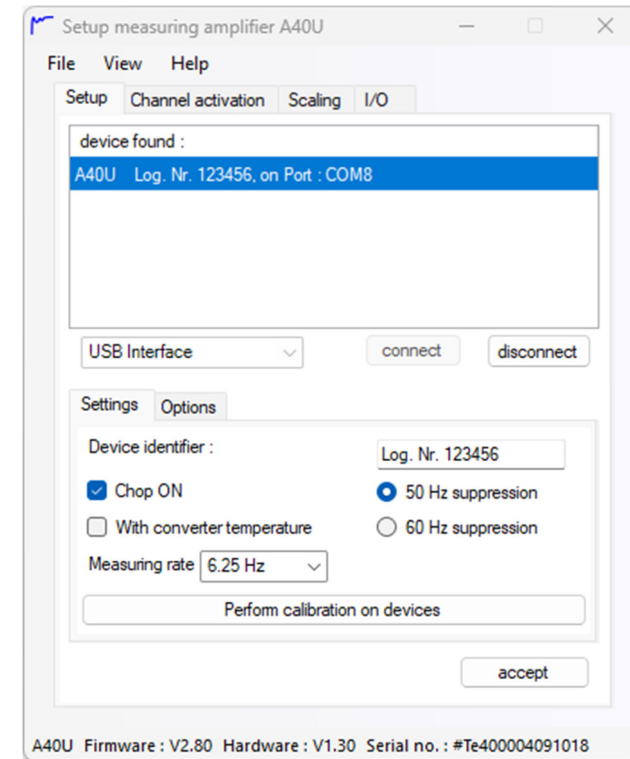

The measuring amplifier does not require sporadic auto-calibration, but internal device calibration can be performed manually.

Channel activation, user designation, user unit

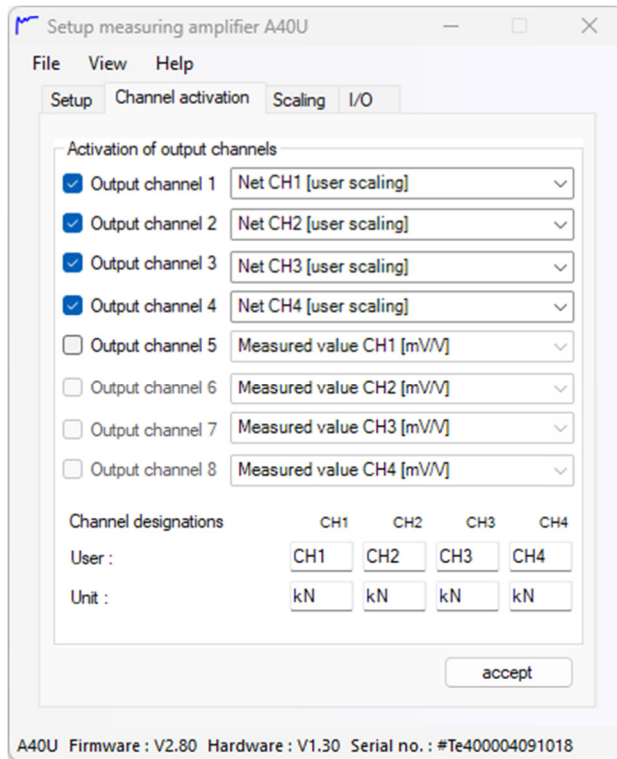

Assign the desired measured values to the output channels. The names of the user parameter sets [CH1...4] can be changed if desired. The display will then show, for example, CH1 Net.



The user unit is also displayed in the measured value display and is used in X-Link Ready for automatic layer summarisation.

Some measured values, such as the device temperature, the AD converter raw values, or the bridge detuning in [mV/V], are not scalable. User scaling is performed via the AD converter raw value with corresponding bridge detuning using a 2..11-point scaling or a polynomial scaling.

Perform user scaling

User scaling can be performed in two different ways, either multipoint scaling or polynomial scaling.

Multi-point scaling

Where the points are assigned manually (e.g. according to the data sheet) or via load steps of a sensor using a testing machine. In the latter case, it is possible to read in the measured value [mV/V] at the corresponding load and enter the user-scaled value.



The decimal point of the user-scaled value is set at the first decimal place. Specify how many decimal places you require and enter the first decimal place accordingly. In the following example, three decimal places are required for user scaling.

You could also perform scaling in [mV/V] to obtain user scaling in [mV/V], with the advantages of multi-point scaling/polynomial scaling. (Linearisation)

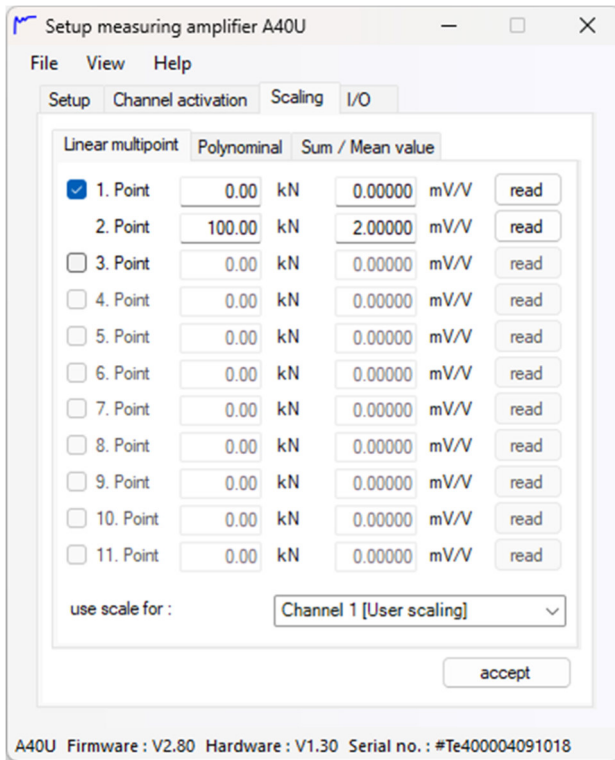

To release further points, tick the checkbox next to the corresponding points.



The multi-point scaling of the corresponding hardware channel is active if the check mark in point 1 is set. (Otherwise, the polynomial function is active)

The decimal point of the input variable [mV/V] cannot be changed, as it was set during device calibration.

Perform the scaling for hardware channels 1...4 according to your specifications. To do this, select the corresponding «Channel x [user scaling]»

Polynomial scaling

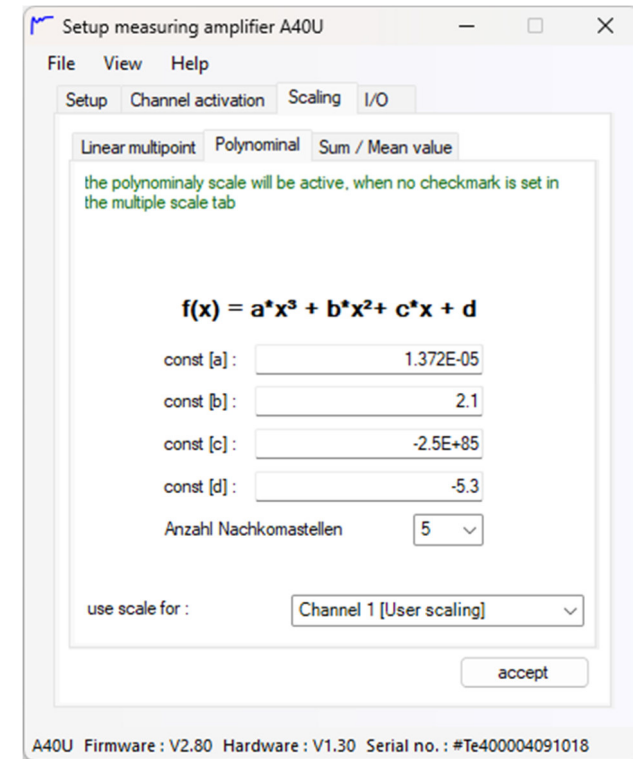

For example, use EXCEL to calculate a polynomial function with 4 constants and enter the values accordingly.



To insert the values into the respective constants, you must do this with the mouse (right-click Insert).

Decimal and scientific entries are permitted, as shown in the example above.

Summation and averaging

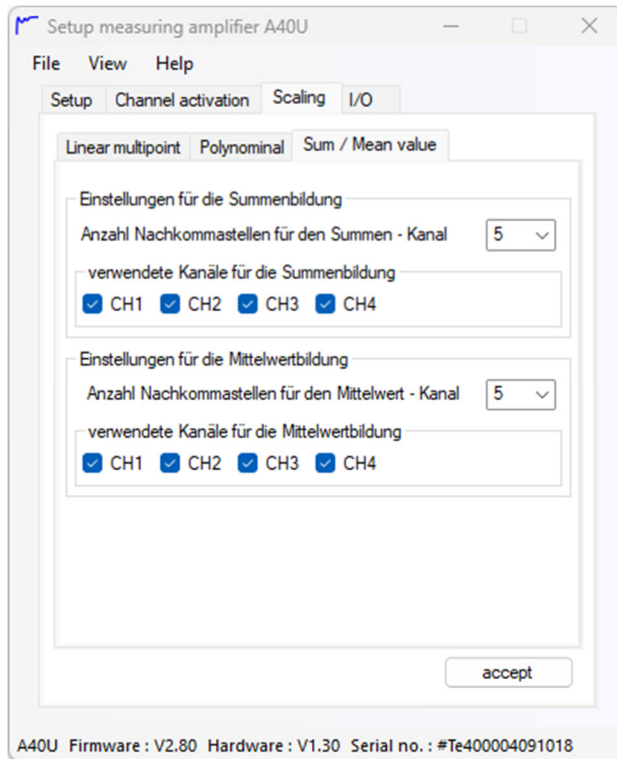

If a sum or average value is assigned to an output channel, the hardware channels (CH1...CH4) that are activated here are used. The number of decimal places can be selected separately for each channel.



If the sum/mean value has more than 7 digits without a decimal point, an overflow is output. In this case, reduce the number of decimal places in the corresponding sum/mean value calculation.

Activate and set limit values

The measuring amplifier has 8 limit value pairs. These are visually displayed in the respective measured value display. In the measuring programme, a sound file can be assigned to the limit values, which is played when active.

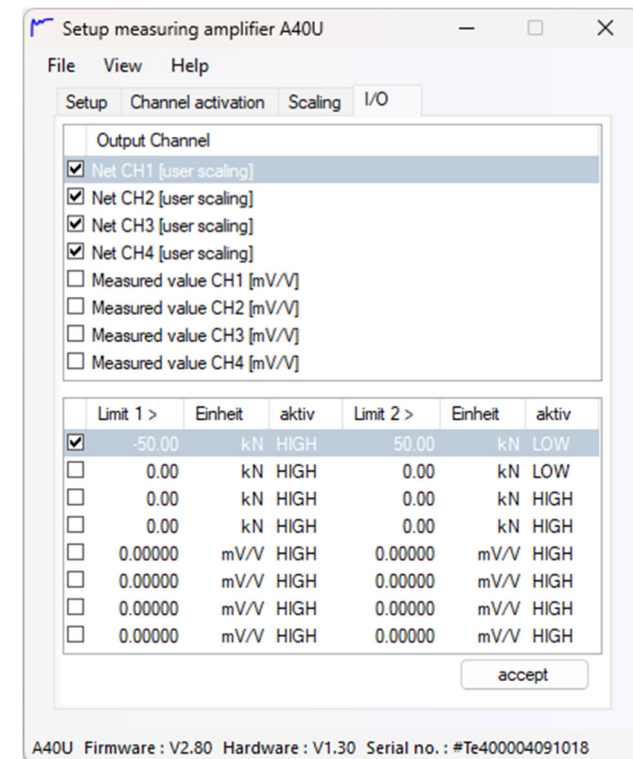

The current output channels correspond to the settings you have made in the channel activation and serve only as an overview of the limit value settings, as does the check mark that indicates which output channel(s) are currently active. (Top)

To activate a limit value pair, click the checkbox for the limit value pair you want to activate. The assignment is displayed in grey.



The decimal points of the respective limit value pairs are adopted from the scaling performed. In this case, from the mean value CH1..2 [user scaling] with 2 decimal places.

To enter the limit values, e.g., in Limit >1, double-click in the Limit 1 field (e.g., Limit 1 > of "Net CH1 [user scaling]") and enter -50.00.

To change the switching direction, double-click in the respective field under active and select between Low / High. (For example, active HIGH means that in our example, the limit value of "Net CH1 [user scaling]" is triggered when it is greater than -50.00kN.

Proceed immediately with limit 2

In our example, limit 2 responds by deactivating the limit value when the measured value exceeds 50.00kN.



Hysteresis is not supported by the measuring amplifier

Load / save settings

All settings made on the device can be saved and loaded. Select «File» in the menu to save/load settings



Load settings:

You can choose exactly what you want to load. Select the appropriate option.

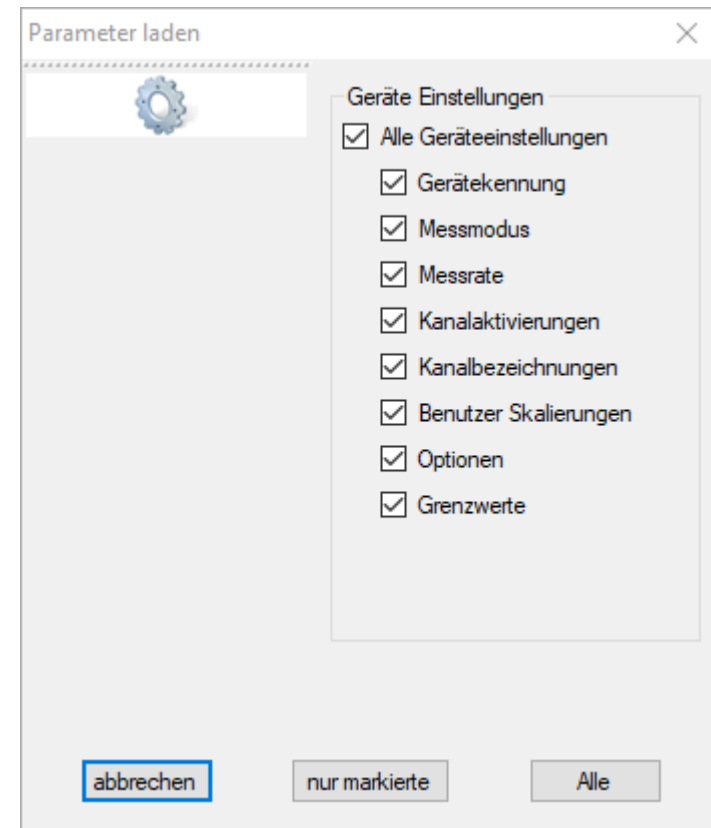

Page view Printer selection Print settings

To do this, select «File» > «Page view» from the menu.

The device settings can also be printed out so that a log can be filed after calibration.

Example page view:



Select a printer under Printer Selection and print the page(s)

Settings from amplifier A40U :



Serial number : #Te400004091018
 Firmware version : 2.80
 Hardware version : 1.30

Amplifier settings :

Device identifier : Log. Nr. 123456
 CHOP : On, Without converter temperature, 50 Hz suppression, Sample rate : 6.25 Hz
 Options : Tare values will be saved, power down protected
 Measurement values in mV/V will be set to zero

Channel activation (active output channels) :

active Output Channel 1 : Net CH1 [user scaling]
 active Output Channel 2 : Net CH2 [user scaling]
 active Output Channel 3 : Net CH3 [user scaling]
 active Output Channel 4 : Net CH4 [user scaling]
 inactive Output Channel 5 : Measured value CH1 [mV/V]
 inactive Output Channel 6 : Measured value CH2 [mV/V]
 inactive Output Channel 7 : Measured value CH3 [mV/V]
 inactive Output Channel 8 : Measured value CH4 [mV/V]

Channel designations :

	CH1	CH2	CH3	CH4
User :	CH1	CH2	CH3	CH4
Unit :	kN	kN	kN	kN

Einstellungen für die Summenbildung :

Nachkommastellen 5
 Verwendete Kanäle CH1 CH2 CH3 CH4

Einstellungen für die Mittelwertbildung :

Nachkommastellen 5
 Verwendete Kanäle CH1 CH2 CH3 CH4

Channel 1 user scale : (multipoint scale)

1 .Point	active	0.00kN	equals	0.00000mV/V
2 .Point		100.00kN	equals	2.00000mV/V
3 .Point	inactive	0.00kN	equals	0.00000mV/V
4 .Point	inactive	0.00kN	equals	0.00000mV/V
5 .Point	inactive	0.00kN	equals	0.00000mV/V
6 .Point	inactive	0.00kN	equals	0.00000mV/V
7 .Point	inactive	0.00kN	equals	0.00000mV/V
8 .Point	inactive	0.00kN	equals	0.00000mV/V
9 .Point	inactive	0.00kN	equals	0.00000mV/V
10 .Point	inactive	0.00kN	equals	0.00000mV/V
11 .Point	inactive	0.00kN	equals	0.00000mV/V

Channel 2 user scale : (multipoint scale)

1. Point	active	0.00kN	equals	0.00000mV/V
2. Point		100.00kN	equals	2.00000mV/V
3. Point	inactive	0.00kN	equals	0.00000mV/V
4. Point	inactive	0.00kN	equals	0.00000mV/V
5. Point	inactive	0.00kN	equals	0.00000mV/V
6. Point	inactive	0.00kN	equals	0.00000mV/V
7. Point	inactive	0.00kN	equals	0.00000mV/V
8. Point	inactive	0.00kN	equals	0.00000mV/V
9. Point	inactive	0.00kN	equals	0.00000mV/V
10. Point	inactive	0.00kN	equals	0.00000mV/V
11. Point	inactive	0.00kN	equals	0.00000mV/V

Channel 3 user scale : (multipoint scale)

1. Point	active	0.00kN	equals	0.00000mV/V
2. Point		100.00kN	equals	2.00000mV/V
3. Point	inactive	0.00kN	equals	0.00000mV/V
4. Point	inactive	0.00kN	equals	0.00000mV/V
5. Point	inactive	0.00kN	equals	0.00000mV/V
6. Point	inactive	0.00kN	equals	0.00000mV/V
7. Point	inactive	0.00kN	equals	0.00000mV/V
8. Point	inactive	0.00kN	equals	0.00000mV/V
9. Point	inactive	0.00kN	equals	0.00000mV/V
10. Point	inactive	0.00kN	equals	0.00000mV/V
11. Point	inactive	0.00kN	equals	0.00000mV/V

Channel 4 user scale : (multipoint scale)

1. Point	active	0.00kN	equals	0.00062mV/V
2. Point		300.00kN	equals	3.00000mV/V
3. Point	inactive	0.00kN	equals	0.00000mV/V
4. Point	inactive	0.00kN	equals	0.00000mV/V
5. Point	inactive	0.00kN	equals	0.00000mV/V
6. Point	inactive	0.00kN	equals	0.00000mV/V
7. Point	inactive	0.00kN	equals	0.00000mV/V
8. Point	inactive	0.00kN	equals	0.00000mV/V
9. Point	inactive	0.00kN	equals	0.00000mV/V
10. Point	inactive	0.00kN	equals	0.00000mV/V
11. Point	inactive	0.00kN	equals	0.00000mV/V

Limit switch settings :

1. Pair of limit values	Source	Threshold	active
inactive : Limit switch 1 >	Net CH1 [user scaling]	0.00kN	HIGH
inactive : Limit switch 2 >	Net CH1 [user scaling]	0.00kN	HIGH

Limit switch settings :

2. Pair of limit values	Source	Threshold	active
inactive : Limit switch 1 >	Net CH2 [user scaling]	0.00kN	HIGH
inactive : Limit switch 2 >	Net CH2 [user scaling]	0.00kN	LOW

Limit switch settings :

3. Pair of limit values	Source	Threshold	active
inactive : Limit switch 1 >	Net CH3 [user scaling]	0.00kN	HIGH
inactive : Limit switch 2 >	Net CH3 [user scaling]	0.00kN	HIGH

Limit switch settings :

4. Pair of limit values	Source	Threshold	active
inactive : Limit switch 1 >	Net CH4 [user scaling]	0.00kN	HIGH
inactive : Limit switch 2 >	Net CH4 [user scaling]	0.00kN	HIGH

Limit switch settings :

5. Pair of limit values	Source	Threshold	active
inactive : Limit switch 1 >	Measured value CH1 [mV/V]	0.00000mV/V	HIGH
inactive : Limit switch 2 >	Measured value CH1 [mV/V]	0.00000mV/V	HIGH

Limit switch settings :

6. Pair of limit values	Source	Threshold	active
inactive : Limit switch 1 >	Measured value CH2 [mV/V]	0.00000mV/V	HIGH
inactive : Limit switch 2 >	Measured value CH2 [mV/V]	0.00000mV/V	HIGH

Limit switch settings :

7. Pair of limit values	Source	Threshold	active
inactive : Limit switch 1 >	Measured value CH3 [mV/V]	0.00000mV/V	HIGH
inactive : Limit switch 2 >	Measured value CH3 [mV/V]	0.00000mV/V	HIGH

Limit switch settings :

8. Pair of limit values	Source	Threshold	active
inactive : Limit switch 1 >	Measured value CH4 [mV/V]	0.00000mV/V	HIGH
inactive : Limit switch 2 >	Measured value CH4 [mV/V]	0.00000mV/V	HIGH

Save tare and zero values in a power failure-proof manner

The tare and zero values can be stored in the device EEPROM in a power failure-proof manner so that they are not lost in the event of a power failure.

To do this, select the «Options» tab

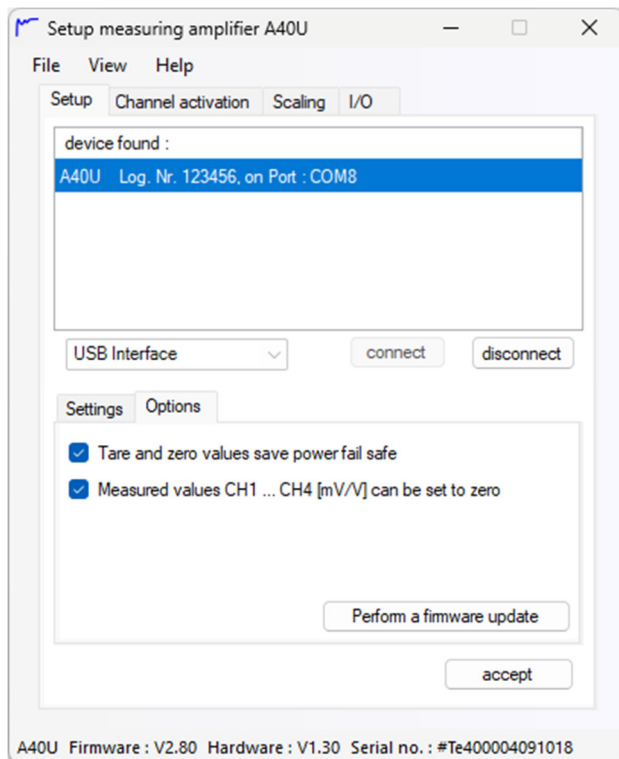

Activate tare and zero values, save them as fail-safe and apply the setting.

Measured values [mV/V] Zero-adjustable

The measured value «bridge offset» in [mV/V] is an absolute value. This option was introduced to keep it resettable to zero.

To do this, select the «Options» tab

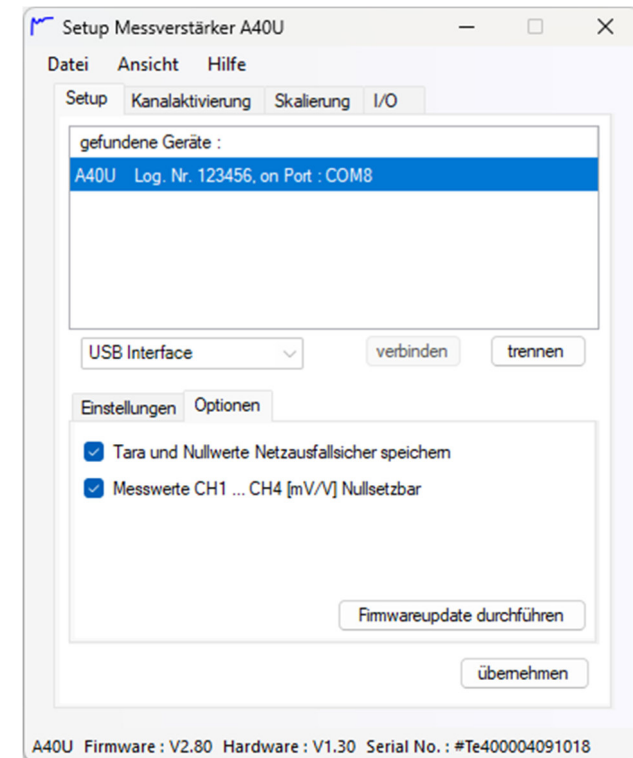

Perform firmware update

To do this, select the «Options» tab and scroll down.

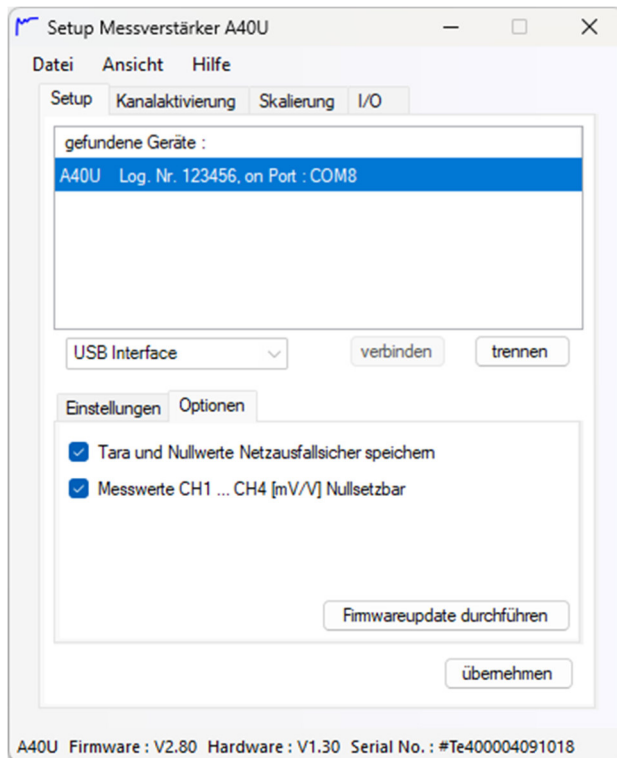

The device's operating system (firmware) can be updated. Follow the instructions displayed on the screen.



Only activate this function if you have the appropriate update and an update is required.

Once the firmware update has started, communication must not be interrupted!



If an error occurs (timeout, firmware not for this device, or not available), the device can be restored to operational status with the current firmware as follows, provided that the flash memory has not yet been deleted:

Disconnect the power cable and wait until the device is de-energised (support capacitors in the power supply unit discharged). The power cord can then be reconnected and the device switched on using the I/O button on the front of the device.

The LED display will show 'Load...' again. Repeat the procedure 5 times. The device will then be ready for operation again with the active firmware version.

If the procedure does not restart the device in the event of an error, the device's flash memory has been deleted. In this case, firmware MUST be loaded.

In the event of an error, send the device to the manufacturer with a description of the error.



During an active firmware update, the update status is shown on the LED display.

Measurement value display in the setup program

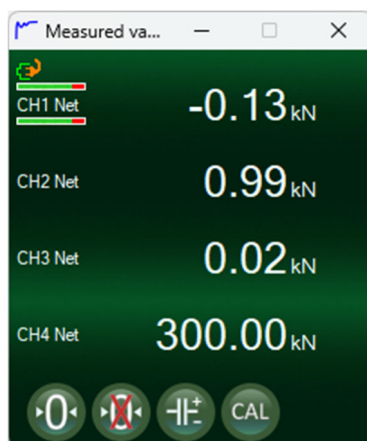

The measured value display in the setup programme shows 8 measured values, depending on the activated output channels.

Meaning of the buttons below the display:



Tare / zero the measured value



Reset peak values



Perform auto-calibration once



Taring / Zeroing Undo

Switching the device on/off

To turn on the device, connect the cable of the supplied power adapter to the device socket and press the «ON» button on the front of the device.

To switch off the device, press the “ON” button for approx. 2 seconds. The green LED flashes, all three LEDs light up, and the “ON” button can be released. The device then switches off. Alternatively, you can disconnect the power supply from the device.

Nameplate

The pin assignment of the full bridge can be found on the type plate on the rear of the device.

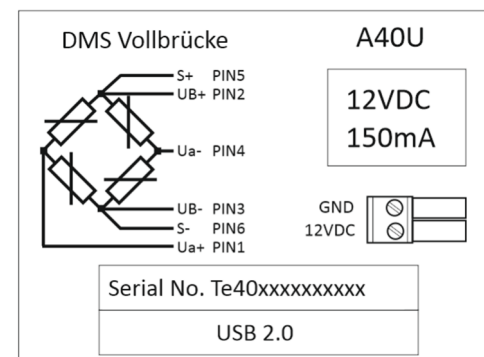

Sensor connection

The sensors are connected via 4 x 6-pin RJ12 6P6C sockets on the rear of the device using 6-wire technology..

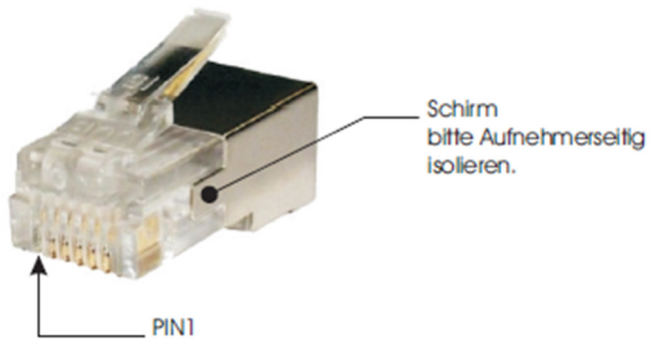

DMS full bridge 60...1000Ohm

- PIN 1 positive output voltage Ua+
- PIN 2 positive bridge voltage UB+
- PIN 3 negative bridge voltage UB-
- PIN 4 negative output voltage Ua-
- PIN 5 positive sense line S+
- PIN 6 negative sense line S-

Shield is clamped to the housing over a large area at RJ12 6P6C

Check whether an update is available

To do this, select «Help» -> «Info» from the menu.

To make software maintenance easier for you, you have the option of performing a manual update check. This is only done at your request by clicking on the «Check for updates» button. You must have an active connection to the internet. After the check, you will be informed if a newer software version is available. Click on the «More information» hyperlink to find out what changes have been made.



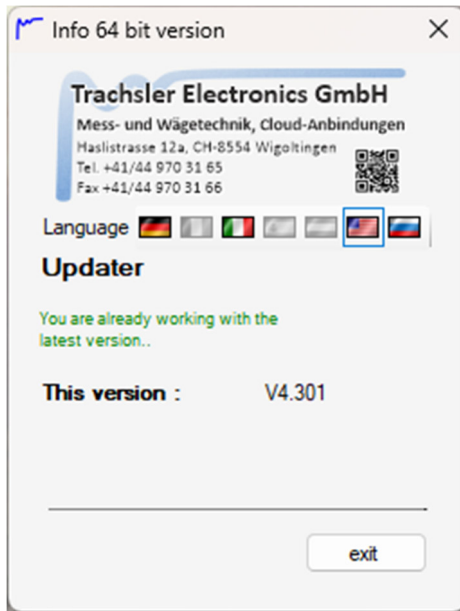

No statistics are kept, no personal data is collected, and no data is sent from your computer to a server. Data transfer is limited solely to reading data and, if necessary, downloading software-related components..



A downloaded version of the programme will be saved to your desktop.

Before the new setup programme can be installed, the old version must be uninstalled. To do this, you must have administrator rights.

Select user language

If you wish to change the user language of the setup programme, select the desired language using the flags. The language will be available after restarting the programme.

Technical specifications

Technical data :

Device Type	A40U	A40UMRD	A40W	A40WD
Interface	USB	USB / Mobile 4G Real Time Clock Cloud Connection	WLAN	WLAN Cloud Connection
Accuracy class	0.02			
Bridge supply voltage DC	V	5		
Connectable sensors : Strain Gauges full bridge 6-wire technology	Ohm	120...1000		
Maximum cable length	m	20		
Sensor connection		RJ12 6p6c, shielded		
Measuring / bridge adjustment range	mV/V	± 7mV/V		
AD converter type		Sigma-Delta (Σ-Δ)		
Internal resolution	bit	24		
User - scales per channel		2 ... 11 Points, or polynomial function of 3rd degree with 4 constants		
Filter Converter Digitalfilter		50Hz / 60Hz suppression selectable Notch - Filter (depending on measuring frequency)		
Internal measuring frequency range	Hz	2 channels synchronous 0.625 ... 4800		
Scaled data transmission	Hz	Measured values /s per channel with 4pcs. enabled output channels 0.625 ... 1200		
* Linearity deviation	%	<0.004		
* Temperature influence per K [CH1] to zero on the measuring range	%	After 15 min operating time <0.005 <0.0025		
Peak value memory		2 pcs. per output channel (user-scaled)		
Limit values (in measured value status)		2 pcs. per output channel can be defined		
Nominal temperature range	°C	0 ... +40		
Supply voltage DC Ripple max.		6.5 ... 13.5V ± 200mV		
Current consumption at 12VDC: switched on automatically switched off		< 180mA ---	180 ... 500mA < 500nA	250 ... 350mA ---
Interface Encryption		USB 2.0		IEEE 802.11b, g, und n open, WPA (TKIP), WPA2 (AES), WEP
Cloud Connection		(3G / 4G LTE) SSL / Password protected		Password protected
Protection class		IP 50		
Dimensions [D * W * H]	mm	80 * 64 * 30		
Weight	g	180		

* 2mV/V calibrated, 50Hz filter, chop on, 2.5Hz measuring rate